

PRODUCT DETAILS

SULO® 660L

25 YEAR PARTNERSHIP WITH SULO



- 1 Flat Lid
- 2 Handle / handle recess
- 3 Handles with handle bar, rear 2x
- 4 Marking areas

- A Body
- B DIN comb lifting system, double stage
- C Stacking ribs
- D Marking areas
- E Ergonomic handles lateral 4x
- F Chip nest as standard
- G Functional castors 2x
- H Swivel castors 2x



OUR MAJOR CLIENTS



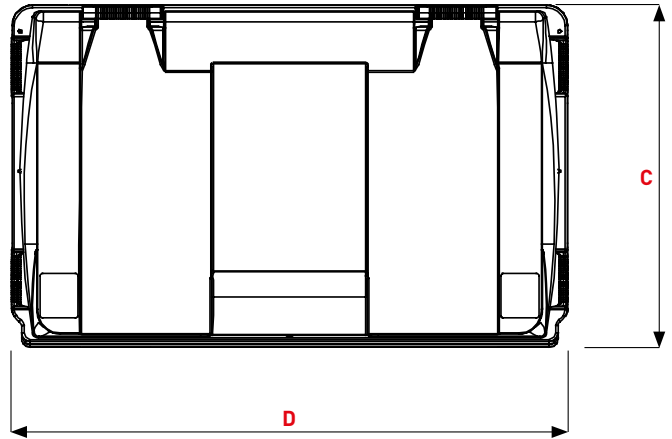
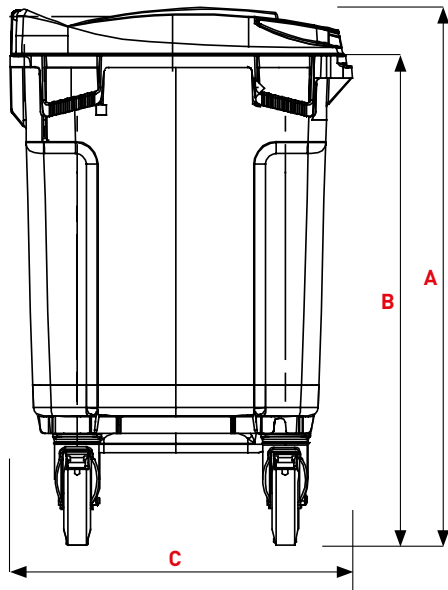

STANDARD LID

Dimensions (mm)

A Height total ~	1165
B Comb height ~	1070
C Bin depth ~	775
D Width total ~	1265

Weights

Volume nominal (L)	660
Empty weight (kg) ~ EN 840 Norm	37,3
Max. filling weight (kg) ~	264