

PRODUCT DETAILS

SULO® 120L

25 YEAR PARTNERSHIP WITH SULO



- 1 Standard Lid
- 2 Handles 2x
- 3 Lid rivet 2x
- 4 Marking areas

- A. Body reinforced with beads
- B. Continuous handle bar
- C. DIN comb lifting system, double stage
- D. SULO sticker / Marking areas
- E. External wheels
- F. Chip nest as standard
- G. Lateral grip surfaces with wave profile



OUR MAJOR CLIENTS



EMAAR

NAKHEEL



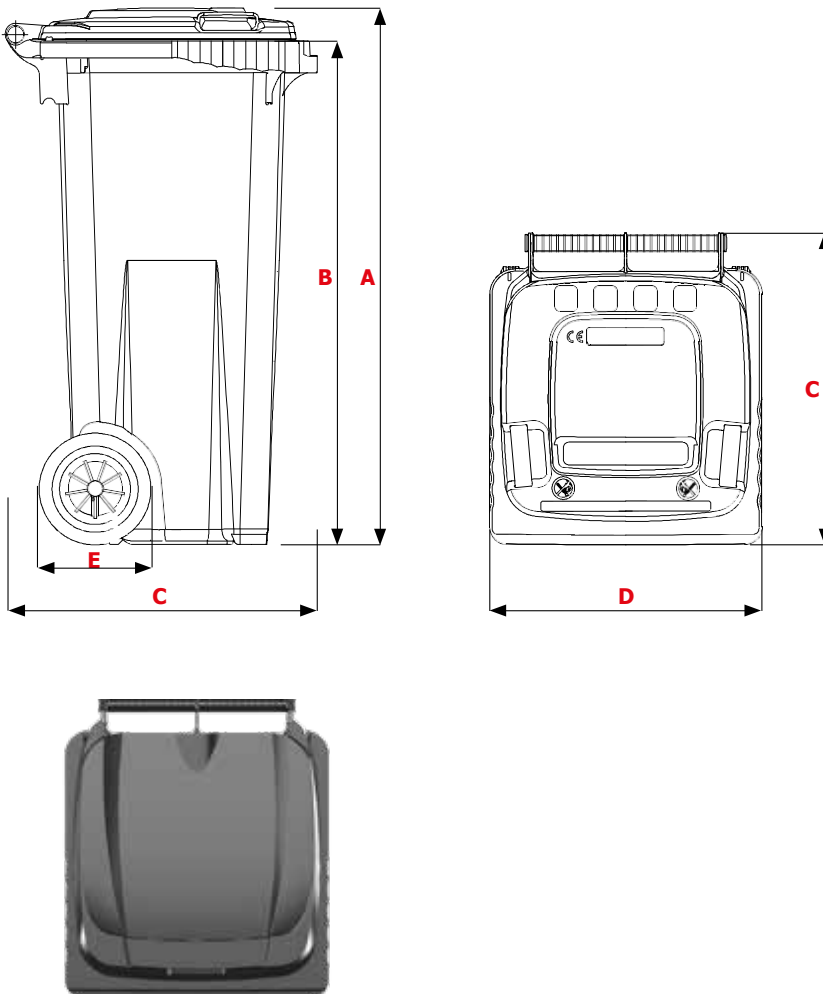

CLIP LID

Dimensions (mm)

A Height total ~	954
B Comb height ~	889
C Bin depth ~	558
D Width total ~	480
E Wheel diameter ~	200

Weights

Tubular axle	
Nominal volume (L)	120
Empty weight (kg) ~	7,2
Max. filling weight(kg) ~	48
Max. total weight (kg) ~	60