

PRODUCT DETAILS

SULO® 120L

25 YEAR PARTNERSHIP WITH SULO



- 1 Dome Lid
- 2 Handle / recessed grip
- 3 Lid handles lateral 2x
- 4 Finger guard
- 5 Marking areas
- 6 Lid opening pegs 2x
- 7 Lid hinge 2x
- 8 Push-buttons to close the domed lid

- A Body reinforced with beads
- B DIN comb lifting system, double stage
- C Stacking ribs
- D SULO sticker / Marking areas
- E Ergonomic handles lateral 4x
- F Chip nest as standard
- G Lifting trunnion
- H Functional castors 2x
- I Double stop break 2x
- J Castors 2x



OUR MAJOR CLIENTS



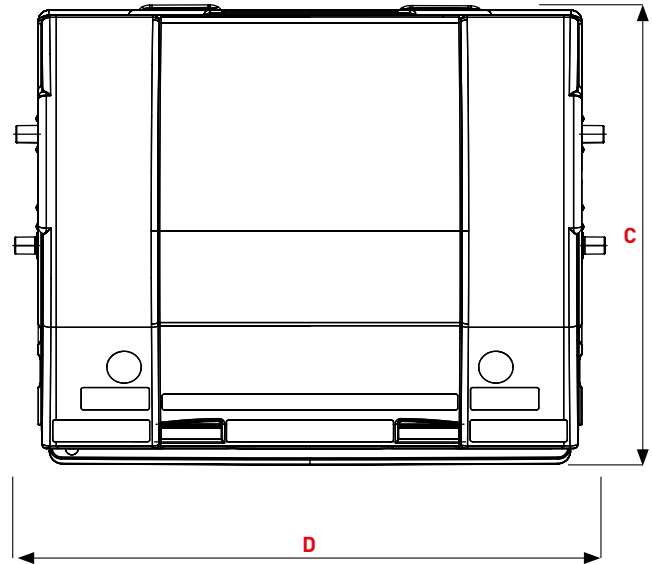
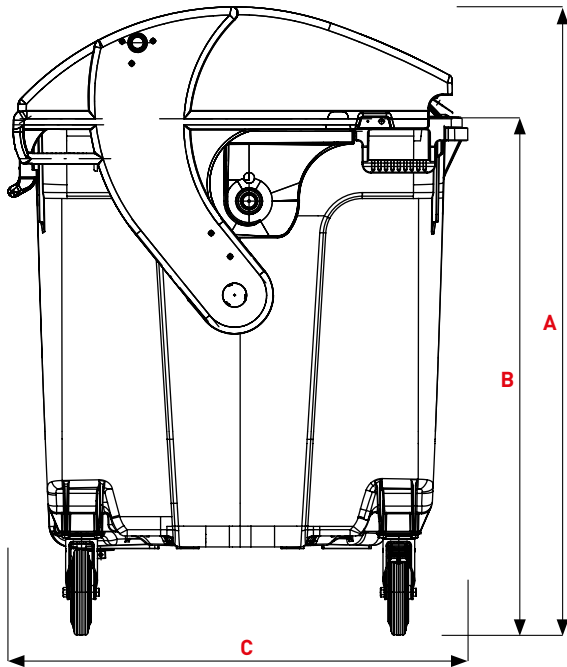

DOMED LID WITH LID-IN-LID

Dimensions (mm)

A Height total ~	1460
B Upper comb edge ~	1205
C Bin depth ~	1060
D Width total ~	1370

Weights

Nominal volume (L)	1100
Empty weight (kg) ~	54
Max. filling weight(kg) ~	440
Max. total weight (kg) ~	510

Dimensions may vary due to production conditions. The specified empty weights are rounded average based on the standard specifications. The actual weight may be different as a result of production conditions and specifications.