

WOOD
MATERIAL : IROKO WOOD.
FINISHING : STAIN DARK WALNUT-4052.

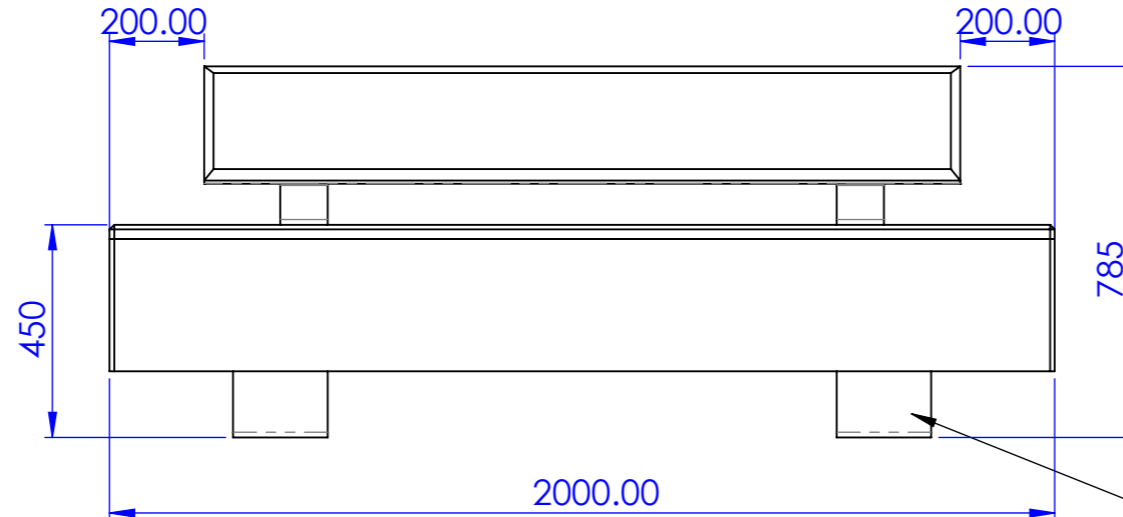
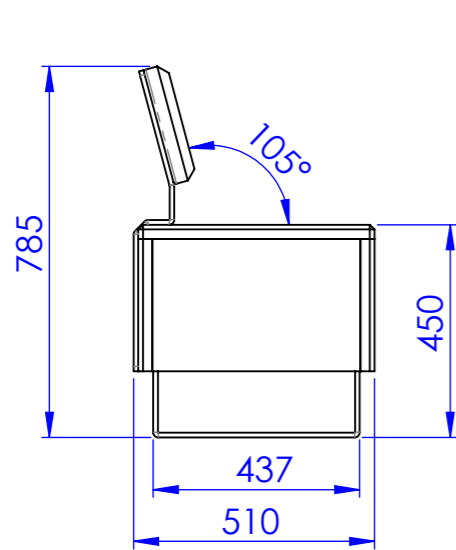

FRAME
MATERIAL : MILD STEEL.
FINISHING : ZINC RICH PRIMER AND POWDER COATING.
(SEMIGLOSSY / MATT / TEXTURED).

MODEL : BANGA II -BENCH (L-2000 X W-500 X H- 785mm).
MATERIAL : MILD STEEL AND IROKO WOOD.
FINISHING : FRAME-ZINC RICH PRIMER AND POWDER COATING.
(SEMIGLOSSY / MATT / TEXTURED).
COLOUR:AS PER REQUIREMENT.
WOOD-STAIN DARK WALNUT-4052.
INSTALLATION : FREE STANDING / SURFACE FIXING.

UNLESS OTHERWISE SPECIFIED: DIMENSIONS ARE IN MILLIMETERS SURFACE FINISH: TOLERANCES:±.5mm LINEAR: ANGULAR:			THIRD ANGLE PROJECTION		DEBURR AND BREAK SHARP EDGES		DO NOT SCALE DRAWING		REVISION: 02		
DRAWN			NAME		SIGNATURE		DATE		TITLE: BANGA II - BENCH		
CHK'D									DWG NO.		
APPV'D									A3		
APPV'D									Reference SO NO.:NA		
APPV'D									SCALE:1:20		
APPV'D									SHEET 1 OF 1		
MFG											
Q.A											

NOTE:Please note that by using this drawing in any format,you are accepting that Bluestream owns the copyright.You are licensed to use this drawing for any product on which Bluestreamme are tendering, and you should not knowingly allow others to copy this drawing.Obtain appropriate licenses from Bluestream if you intend to use the intellectual property rights of Bluestreamme in performing your obligations under any contract.Bluestreamme reserves the right to amend specifications without notice for product improvement.